

Tech Guide

LSA-H2650i Supercharger



Harrop Engineering develops and manufactures premium supercharger kits in Melbourne, Australia and Dayton, Ohio, USA. Through 70 years of automotive performance engineering, Harrop have successfully manufactured and supplied Superchargers to Automotive OEM programmes including TRD, Lotus Cars and Ford Australia. Harrop Engineering is certified to meet ISO9001 standards of quality. OEM quality, performance and vehicle integration are the foundation of Harrop Supercharger kits.



ENGINEERING PERFORMANCE SINCE 1955

11/11/2024

Tech Guide

LSA-H2650i Supercharger



Standard Features

- Optional pulley's available at time of purchase including GripTec variants and overdrive balancers.
- Supercharger manifold incorporates independent drive and throttle body housings allowing flexible throttle body applications without the need to replace the drive assembly.
- A range of 8PK pulleys are available to suit standard LSA drive including GripTec variants .
- Optional Harrop manufactured manifold thermal insulators available at time of purchase.
- OEM fuel lines, rails and upper manifold are direct bolt on.
- A relocation bracket is supplied for the by-pass boost control solenoid valve.
- All standard hoses will fit/connect. (Valley plate breather to throttle body adaptor, booster etc.)
- The design retains the standard LSA type intercooled by-pass system.
- Manifold is machined to accept return style fuel rail system.
- The supercharger manifold is identical in height to factory 1900.

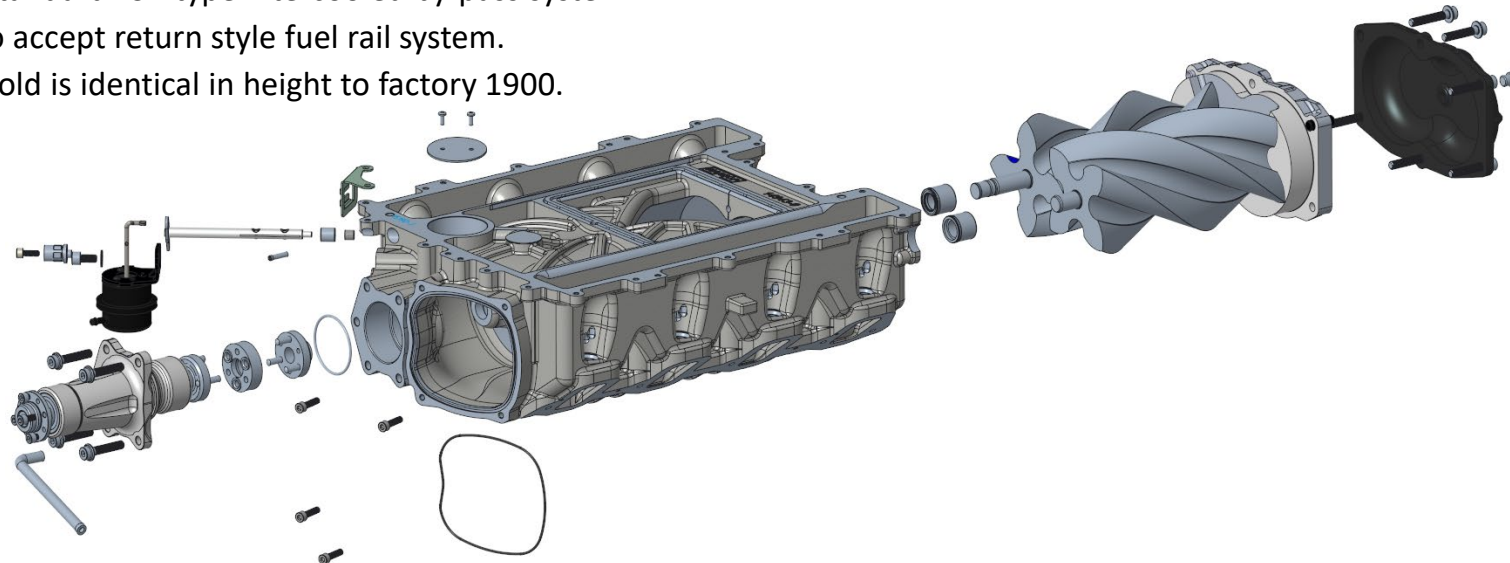

ENGINEERING PERFORMANCE SINCE 1955

11/11/2024



Harrop LSA-H2650i drive pulley matrix

HARROP 2650i LSA DRIVE PULLEY								
DRIVE RATIO	SUPERCHARGER SPEED AT 6600 CRANKSHAFT RPM	SUPERCHARGER PULLEY Ø	SUPERCHARGER PULLEY PART NUMBER	SUPERCHARGER PULLEY DESCRIPTION	CRANK PULLEY Ø	OVERDRIVE CRANK BALANCER	BELT LENGTH	TENSIONER POSITION
3.06	20206	65	99-PLY15004	Pulley S/Chrgr 8PK, 65x30x17.1 Offset, 4x40PCD	199	0%	1650	4
2.84	18763	70	99-PLY15005	Pulley S/Chrgr 8PK, 70x30x17.1 Offset, 4x40PCD	199	0%	1650	4
2.65	17512	75	99-PLY15006	Pulley S/Chrgr 8PK, 75x30x17.1 Offset, 4x40PCD	199	0%	1660	4
2.49	16418	80	99-PLY15007	Pulley S/Chrgr 8PK, 80x30x17.1 Offset, 4x40PCD	199	0%	1660	4
2.34	15452	85	99-PLY15008	Pulley S/Chrgr 8PK, 85x30x17.1 Offset, 4x40PCD	199	0%	1680	4
2.21	14593	90	99-PLY15009	Pulley S/Chrgr 8PK, 90x30x17.1 Offset, 4x40PCD	199	0%	1680	4
3.21	21216	65	99-PLY15004	Pulley S/Chrgr 8PK, 65x30x17.1 Offset, 4x40PCD	209	5%	1660	4
2.99	19701	70	99-PLY15005	Pulley S/Chrgr 8PK, 70x30x17.1 Offset, 4x40PCD	209	5%	1660	4
2.79	18388	75	99-PLY15006	Pulley S/Chrgr 8PK, 75x30x17.1 Offset, 4x40PCD	209	5%	1680	4
2.61	17238	80	99-PLY15007	Pulley S/Chrgr 8PK, 80x30x17.1 Offset, 4x40PCD	209	5%	1700	4
2.46	16224	85	99-PLY15008	Pulley S/Chrgr 8PK, 85x30x17.1 Offset, 4x40PCD	209	5%	1700	4
2.32	15323	90	99-PLY15009	Pulley S/Chrgr 8PK, 90x30x17.1 Offset, 4x40PCD	209	5%	1700	4
3.37	22227	65	99-PLY15004	Pulley S/Chrgr 8PK, 65x30x17.1 Offset, 4x40PCD	219	10%	1700	4
3.13	20639	70	99-PLY15005	Pulley S/Chrgr 8PK, 70x30x17.1 Offset, 4x40PCD	219	10%	1700	4
2.92	19263	75	99-PLY15006	Pulley S/Chrgr 8PK, 75x30x17.1 Offset, 4x40PCD	219	10%	1700	4
2.74	18059	80	99-PLY15007	Pulley S/Chrgr 8PK, 80x30x17.1 Offset, 4x40PCD	219	10%	1725	4
2.58	16997	85	99-PLY15008	Pulley S/Chrgr 8PK, 85x30x17.1 Offset, 4x40PCD	219	10%	1735	4
2.43	16053	90	99-PLY15009	Pulley S/Chrgr 8PK, 90x30x17.1 Offset, 4x40PCD	219	10%	1735	4
3.61	23843	65	99-PLY15004	Pulley S/Chrgr 8PK, 65x30x17.1 Offset, 4x40PCD	234	18%	1725	4
3.35	22140	70	99-PLY15005	Pulley S/Chrgr 8PK, 70x30x17.1 Offset, 4x40PCD	234	18%	1740	4
3.13	20664	75	99-PLY15006	Pulley S/Chrgr 8PK, 75x30x17.1 Offset, 4x40PCD	234	18%	1740	4
2.94	19373	80	99-PLY15007	Pulley S/Chrgr 8PK, 80x30x17.1 Offset, 4x40PCD	234	18%	1755	4
2.76	18233	85	99-PLY15008	Pulley S/Chrgr 8PK, 85x30x17.1 Offset, 4x40PCD	234	18%	1755	4
2.61	17220	90	99-PLY15009	Pulley S/Chrgr 8PK, 90x30x17.1 Offset, 4x40PCD	234	18%	1780	4

Red highlighted cells indicate high Supercharger speed @ 6600 crank rpm – warranty void

Specifying pulley's

If you would like to use the GripTec equivalent the pulley part number should be expressed as the following:

- *Standard Harrop pulley* **99-PLY15008**
- *GripTec equivalent pulley* **99-PLY15008-GT**

Tech Guide

LSA-H2650i Supercharger

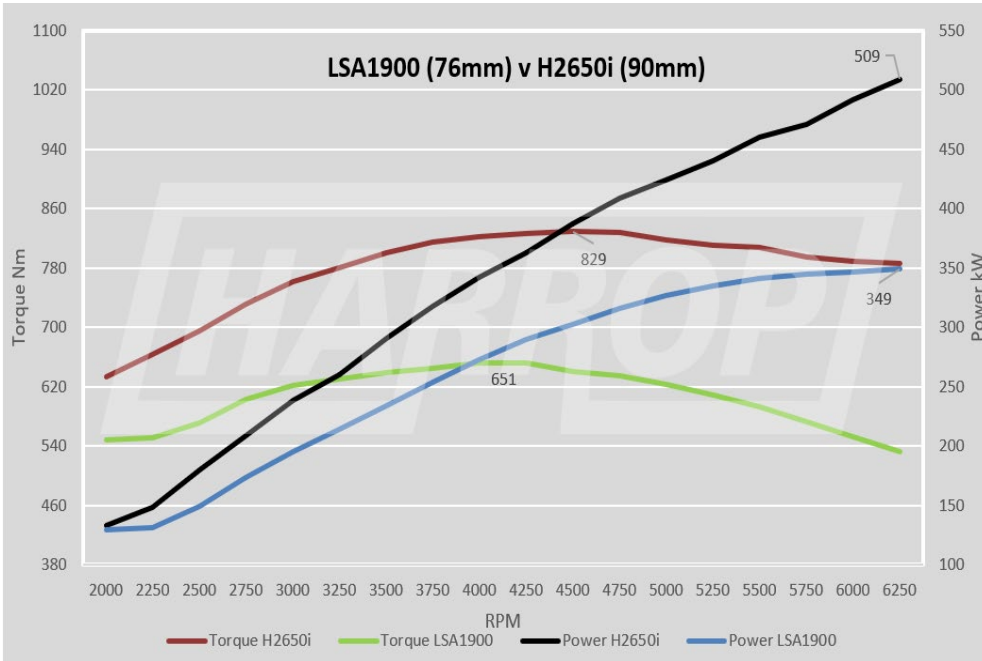

Power and Torque Comparison

Boost Comparison

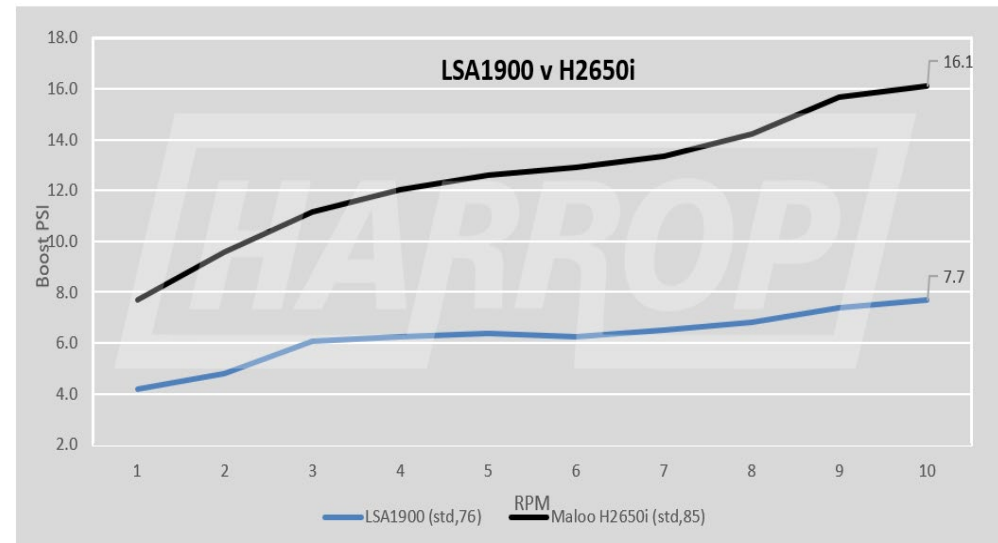

*Data Correction: 3.29 SAE J607 (20.7°C, 1002mBrA, 44%), Fuel 98 RON (93AKI)

ENGINEERING PERFORMANCE SINCE 1955

11/11/2024

LSA-H2650i-RP Supercharger

Key Features:

- High efficiency FDFI 2650 Supercharger
- High efficiency Inlet port geometry for increased high RPM / Boost performance
- Matt Black powder coat
- Manifold assembly p/n **99-AMFD14942-RP**

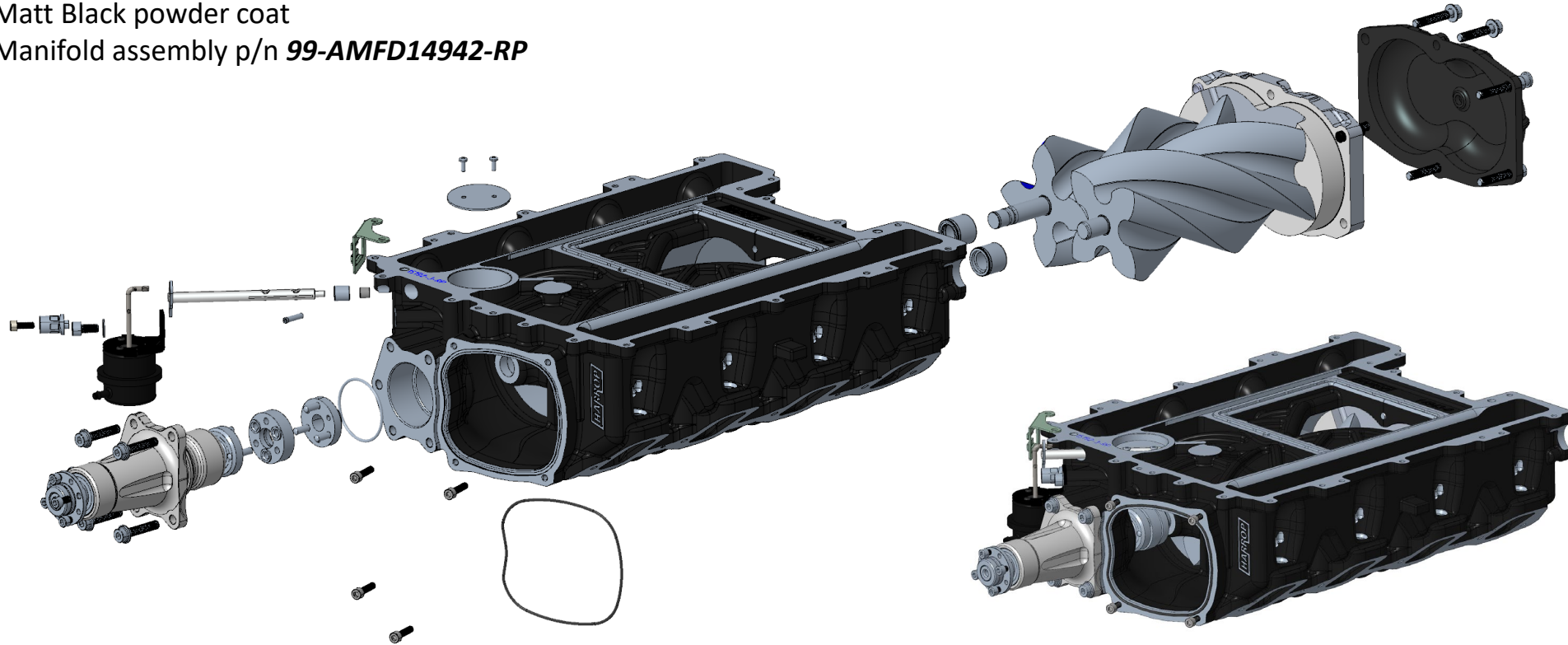

ENGINEERING PERFORMANCE SINCE 1955

11/11/2024

LSA-H2650i & LSA-H2650i-RP Throttle Adaptor/Body Options

- Cast 103mm (LSA throttle position) – 102/103mm throttle bodies - 104x70mm bolt pattern
- Billet 120mm adaptor (“LSA Throttle position”) for LS, LT 120mm throttles - 126x70mm bolt pattern (for use with electric power steer vehicles. Only Idler pulley on LH cylinder head, no P/S pump)
- Integrated 115mm Throttle body (Black powder coat or as cast finish) ETC or Cable actuation

103mm
99-AADP14947

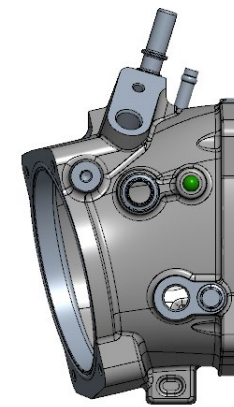

115mm

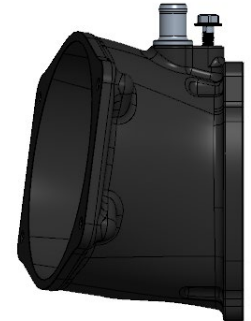
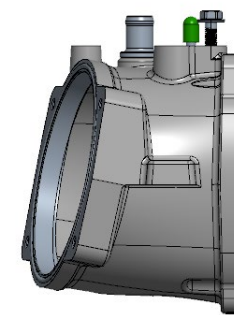

115 Integrated cable (Black)
99-AHSG15529

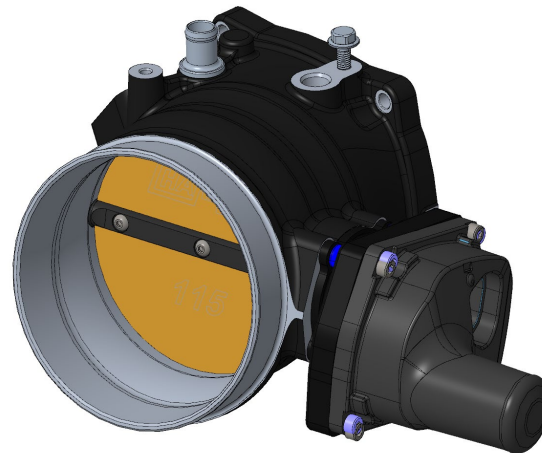
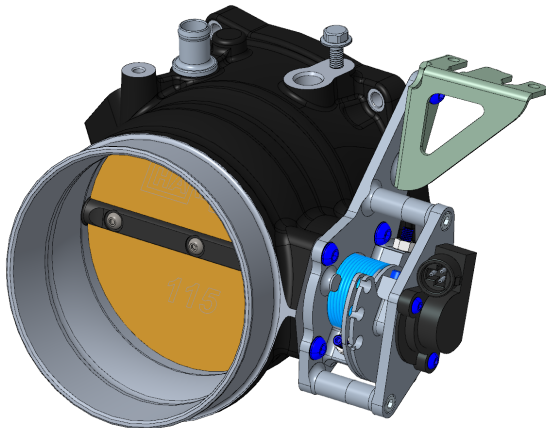

115 Integrated ETC (Black)
99-AHSG15139

Tech Guide

LSA-H2650i Supercharger



Comparative Performance Figures

ENGINE	COMPONENTS	POWER CORRECTION	POWER (Hub)	TORQUE	BOOST	PULLEY RATIO	FUEL
<i>Mainline Hub Dyno</i>							
LS - 427CI	Higgins heads, 10.5CR, T400, Chiller STD H2650I	SAE J1349 2004	1011 hp @ 7400 RPM		19 psi	3.38	E85
LS - 427CI	Higgins heads, 10.5CR, T400, Chiller RP H2650I	SAE J1349 2004	1089 hp @ 7400 RPM		20.5 psi	3.38	E85

ENGINEERING PERFORMANCE SINCE 1955

11/11/2024

